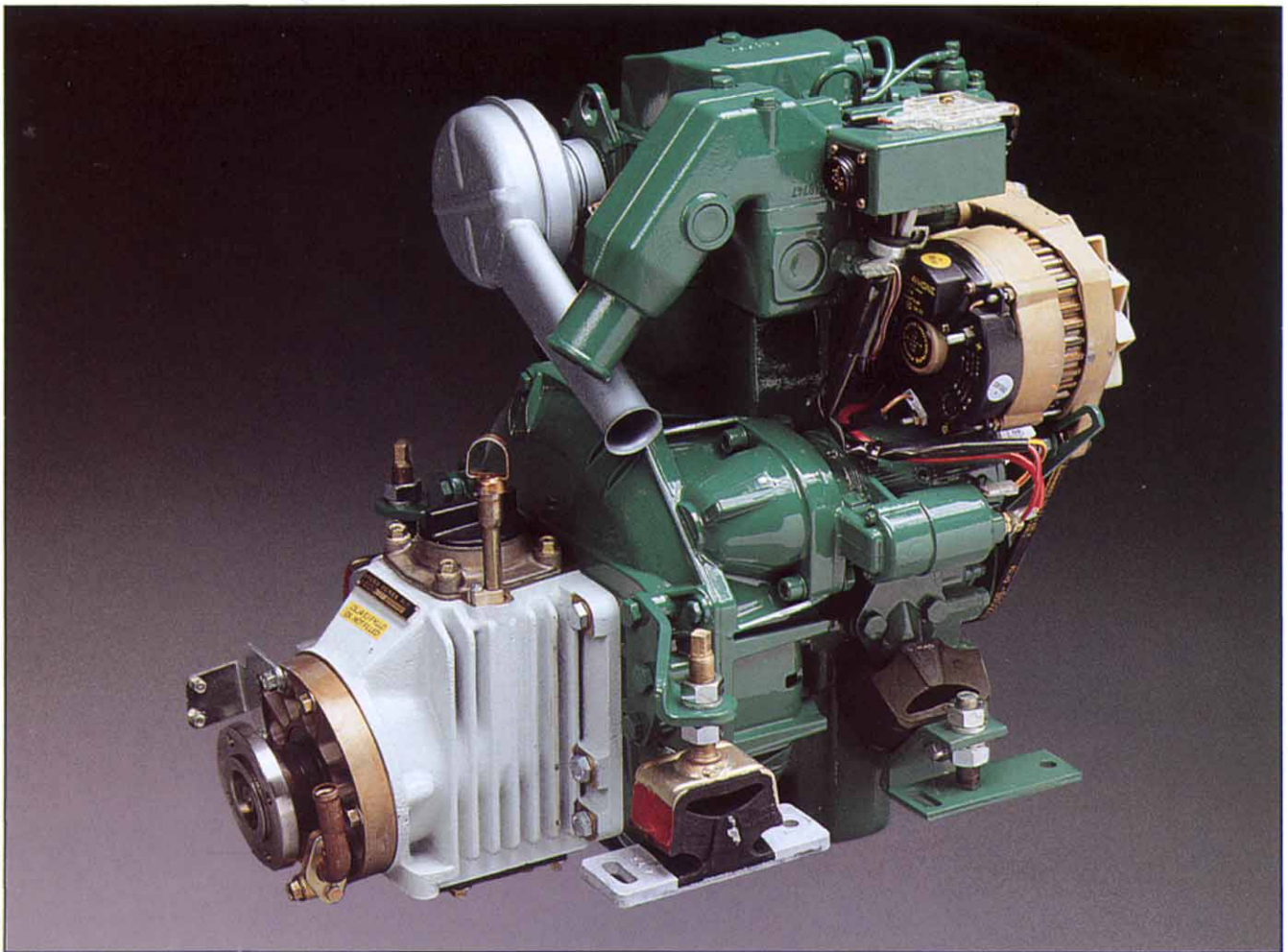

**VOLVO
PENTA****2001**

**1-cylinder, 4-stroke, direct injected marine diesel
with reverse gear, V-drive or S-drive. Propeller shaft output,
— 6,6 kW (9 hp) at 3200 r/min.**

2001 is the designation of the 1-cylinder variants of Volvo Penta's 2000 Series. Shorter and narrower than previously available. Designed and manufactured for marine use ensuring long service life and high standards of comfort.

Direct injected, easily started and fuel efficient. With electric starting as standard. Large flywheel, decompression lever and fuel enrichment device for easy starting. A 12-volt marine electrical system with a 14V/50A alternator ensure adequate charging. The engine is carried in vibration-damping rubber mounts.

Cast-iron block and cylinder head with sacrificial anode for additional protection.

All essential service points are easily accessible at the front of the engine: Oil filler cap, oil filter, fuel filter and sea waterpump impeller. The drive belt adjustment, and bleeding of the fuel system are also all done from the front of the engine.

There are three transmission alternatives for the 2000 Series engines, all with an easily operated cone clutch with an anti-slip feature. The R-version is angled down at 7° to facilitate installation and save space. In the V-version (output shaft angled at 20°), the transmission comes complete with bevel gears and a through-running

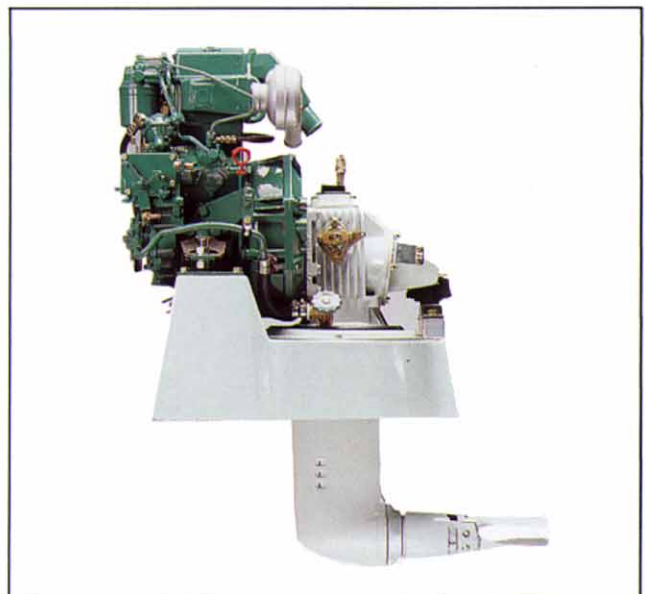

shaft feature for simple alignment. Last but by no means least, the S-version with its very compact and extremely quiet-running concept.

2000
DIESEL SERIES

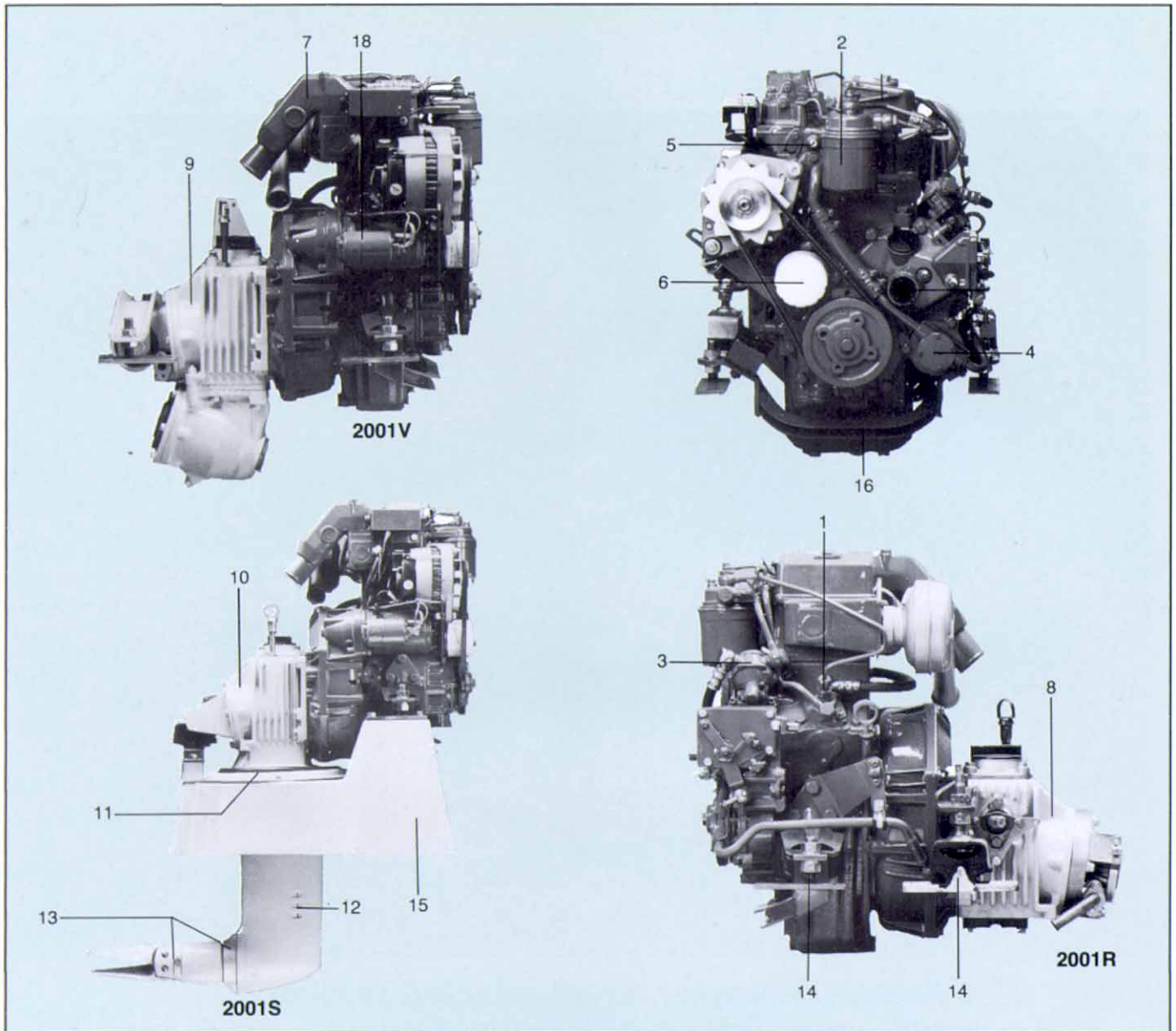

Standard equipment

ENGINE BLOCK

Cylinder block and cylinder head of cast-iron for benefits of corrosion resistance and long-life. Two main bearing crankshaft.

FUEL SYSTEM

Injection pump (1). The fuel system is self-bleeding. Cold starting and stop functions operated by joint pull control. Fuel filter (2) type spin-on, feed pump (3) with manual priming, flexible fuel lines (length 750 mm/30 in.) with pipe connections.

COOLING SYSTEM

Thermostatically controlled raw water cooling with easy access to impeller pump (4). Cylinder head protected from corrosion by sacrificial zinc anode (5).

LUBRICATION SYSTEM

Pressure lubrication with oil filter type spin-on (6) mounted on front of engine. Closed circuit crankcase ventilation.

EXHAUST SYSTEM

Exhaust elbow (7) with water injection and connection for rubber exhaust hose. The elbow can be turned through 90° where necessary to save space.

REVERSE GEAR

R and V versions. Ratio 2.4:1 or 3.0:1. R-version's (8) output shaft angled 7°. V-version's (9) output shaft angled 20° (to engine).

S-DRIVE

S-drive (10) ratio 2.2:1. Complete

with flexible diaphragm (11), sealing ring and mounting to bed. Coolant inlet (12) incorporated in drive leg. Shut-off valve for coolant, sacrificial zinc anode ring (13). Propeller not included as standard.

ENGINE MOUNTS

Model 2001R. Flexible mounting consisting of four rubber mounts with adjustable attaching plates (14) to isolate noise and vibration.

Model 2001V. Flexible mounting consisting of three rubber mounts with adjustable attaching plates to isolate noise and vibration.

Model 2001S. S-drive attached directly to engine. Engine/drive insulated from hull, by a three-point mounting system and a flexible diaphragm. GRP engine bed (15). Engine tie rod (16) to prevent excessive movement in case of running aground.

ELECTRICAL SYSTEM

12 V marine electrical system complete with instrumentation. Alternator (17) with charging capacity 14 V/50 A designed for marine operation. Alternator prepared for installation of double diode unit which automatically distributes the charging current to two independent battery banks.

STARTING SYSTEM

Starter motor (18) output 0,8 kW (1 hp).

INSTRUMENT PANEL

Complete with key switch. Control displays for high engine temperature, low oil pressure and low charge. Acoustic alarm for low oil pressure and high engine temperature. Test button for alarm functions. Switch operated instrument lighting. Extension cable 3 m with plug-in connector. Prewired to accept tachometer (extra accessory).

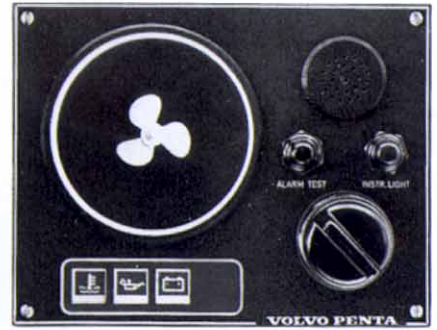

TOOL KIT

Adequate for minor repairs.

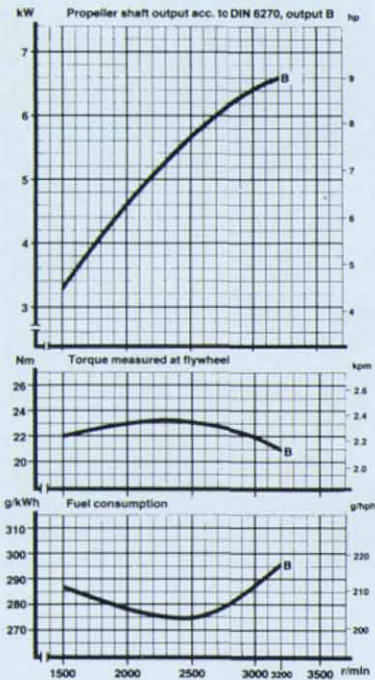

The diagram shows propeller shaft output of a run-in engine of R, V and S types according to DIN 6270 B.

Data

Configuration	4-stroke diesel engine with direct injection
Propeller shaft output*	
2001 R.V.S.	6,6 kW (9 hp) at 3200 r/min
No. of cylinders	1
Bore/Stroke mm (in)	79/87 (3.1/3.4)
Displacement, dm ³ (cu. in)	0.43 (26)
Valve mechanism	Overhead
2001 R.V. (model MS2B) ratio	2.4:1 or 3.0:1
2001 S (model 120B) ratio	2.2:1
Weight 2001 R approx kg (lbs)	112 (247)
Weight 2001 V approx kg (lbs)	118 (260)
Weight 2001 S approx kg (lbs)	126 (278)

* Acc. to DIN 6270 B.

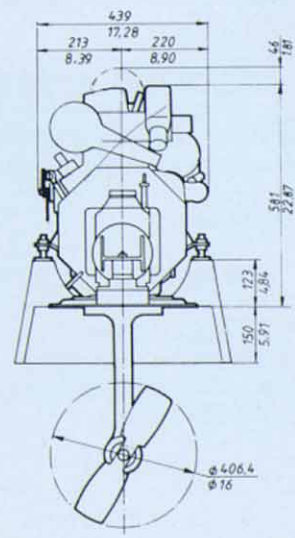
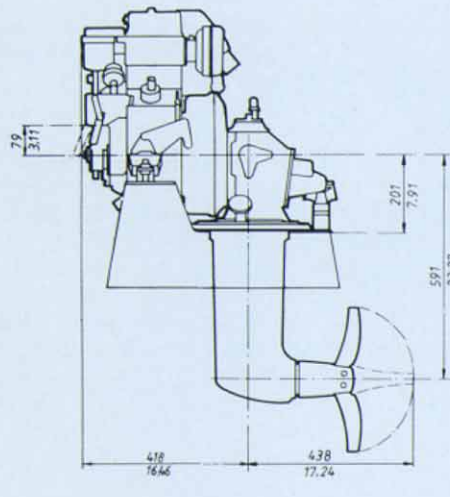
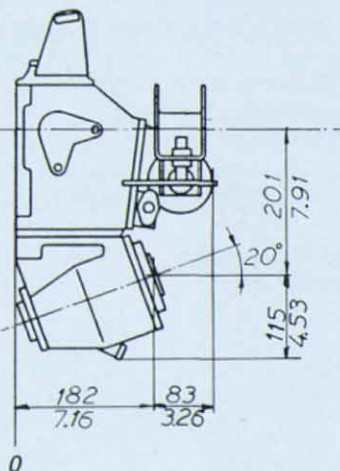
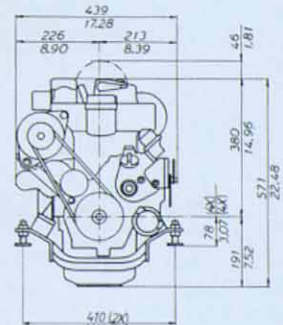
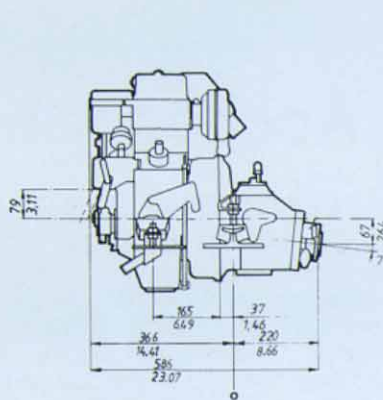

Reverse gear

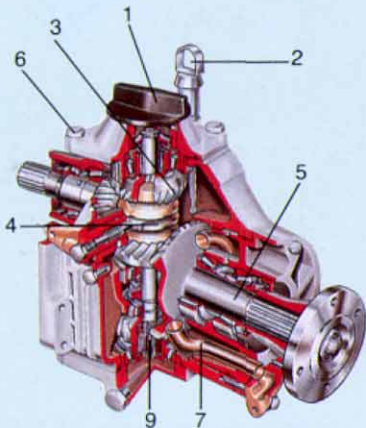

1. Easy access oil filler.
2. Oil dipstick.
3. Spiral bevel gears for quiet, efficient operation.
4. Volvo Penta's patented cone clutch gives smooth quiet engagement of forward and reverse. Single lever control of both speed and forward/reverse.
5. Output shaft with 7° down angle. Enables installation of engine in less space.

V-Drive

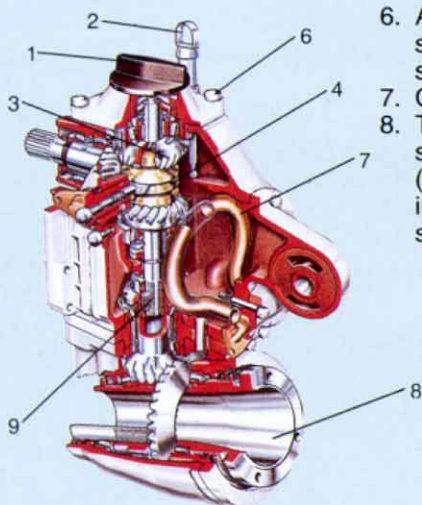

6. All joints have stainless steel screws in stainless steel thread inserts.
7. Coolant pipe for oil cooling.
8. Through-running output shaft featured angled 20° (to engine) facilitates installation and saves space.

S-Drive

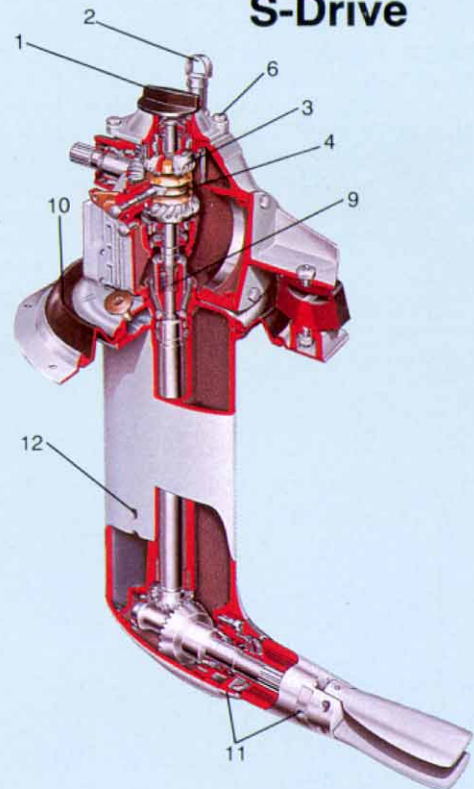

9. Integral slip coupling safeguards against over-loading (e.g. running aground) thereby protecting the transmission.
10. Flexible diaphragm, complete with sealing ring and mounting collar to engine bed.
11. Sacrificial zinc anode ring to counteract corrosion.
12. Coolant intake in leg.

Accessories

FUEL SYSTEM

Electric fuel pump. Pre-filter with water trap and 5/16" copper pipe. Water trap. Fuel tank 18 or 40 litres (4,8 or 10,6 US gal). Inspection plate with connections for fuel filler pipe, feed pipe, fuel gauge and tank ventilation.

COOLING SYSTEM

Sea water inlet with shut-off valve. Sea water filter complete with mountings. Vacuum valve.

EXHAUST SYSTEM

Rubber exhaust hose. Exhaust through hull fitting. Water cooled silencer, complete. Dry exhaust system.

ELECTRICAL SYSTEM and INSTRUMENTATION

Charging distributor for charging of two battery systems. Extra instruments. Tachometer, electric hour counter, fuel and water tank gauges, voltmeter and rudder indicator. Main circuit breaker. Extension cables 3, 5, 7 m (9.8, 16.4 or 23.0 ft). Instrument panel for extra instruments.

CONTROL SYSTEMS

VP single-lever control for engine speed and gear shifting, top mounted or side mounted. Neutral position switch for VP control, pull control, control cables. Steering gears, steering cables, ball joints and yokes for steering cables.

PROPELLER EQUIPMENT 2000R 2000V

Propeller shaft coupling, complete; flexible propeller shaft coupling; propeller shafts, propeller sleeves and stuffing boxes. Complete two and three blade bronze fixed propeller programme.

PROPELLERS S-DRIVE

Two-blade folding with zinc anodes. Two-blade I.O.R fixed. Three-blade fixed.

MISCELLANEOUS

Electrical bilge pump, genuine paints, oils, etc.