

► EMBOUT DE BARRES DE FLÈCHE / TIP OF SPREADERS

EMBOUS CONTINUS / CONTINUOUS TIPS

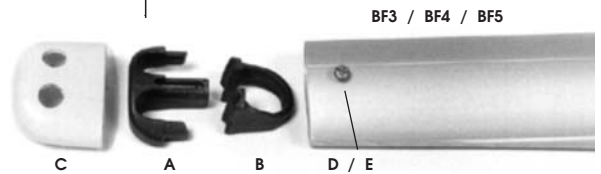
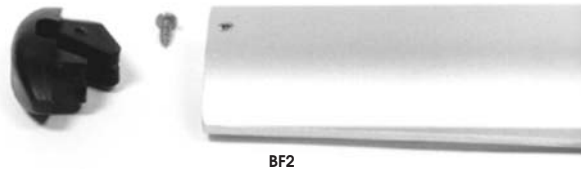
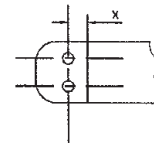

	REF. COMPLETE UNITAIRE UNITARY COMPLETE REF.	CÂBLE MAXI MAXI WIRE	EMBASE BASE B	EMBOUS TIP A	PROTECTION PLASTIQUE PLASTIC PROTECTOR C	VIS SCREW D	ECROU INDES. NYLOC NUTS E	X
						Qt	Qt	
BF2	32602030055			32602030050		28606408009	1	10
BF3	32603030085	Ø 8 mm	32603040083	32603030083	32603050082	28606408009	1	10
BF4	32604030105	Ø 10 mm	32604040103	32604030103	32604050102	28600806040	1	10
BF5	32605030145	Ø 14 mm	32605040143	32605030143	32605050142	28601306050	1	15

EMBOUS DISCONTINUS / DISCONTINUOUS TIPS

	X	Y
BF2	18	
BF3	55	20
BF4	62	20
BF5	69	20

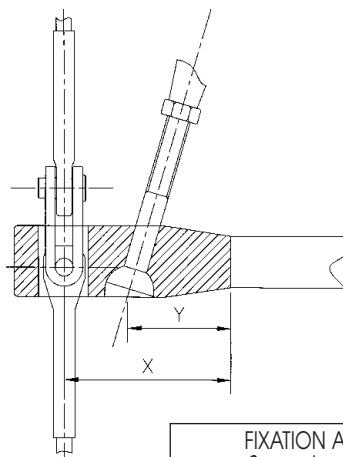

	REF. COMPLÈTE COMPLETE REF.	CÂBLE MAXI MAXI WIRE	EMBOUS TIP	AXE PIN	ECROU INDES. NYLOC NUTS	VIS SCREW	ECROU INDES. NYLOC NUTS	VIS SCREW	Qt	ANNEAU BRISÉ SPLIT RING
BF2	32602010085	V1 Ø 5 mm V2 Ø 4 mm	32602010083	40020208045 Ø 8 mm			28600505000	28601305025		28809000015
BF3	32603010105	V1 Ø 8 mm V2 Ø 7 mm	32603010103	40020310056 Ø 10 mm	28600503000	28600204040	28600506000	28601306040	1	
BF4	32604010145	V1 Ø 12 mm V2 Ø 10 mm	32604010143	40020314078 Ø 14 mm			28600506000	28601306045	2	28803032450
BF5	32605010165	V1 Ø 12 mm V2 Ø 10 mm	32605010163	40020316105 Ø 16 mm	28600505000	28600205055	28600506000	28601306050	1	
	32605010185	V1 Ø 12 mm V2 Ø 10 mm	32605010183	40020318105 Ø 18 mm	28600505000	28600205055	28600506000	28601306050	1	
	32605010205	V1 Ø 14 mm V2 Ø 12 mm	32605010203	400203320105 Ø 20 mm	28600505000	28600205055	28600506000	28601306050	1	
	32605010225	V1 Ø 16 mm V2 Ø 14 mm	32605010223	40020322105 Ø 22 mm	28600505000	28600205055	28600506000	28601306050	1	